

# Model 90-110

## Double Reduction Planetary Gear Reducer

### Flange Mount

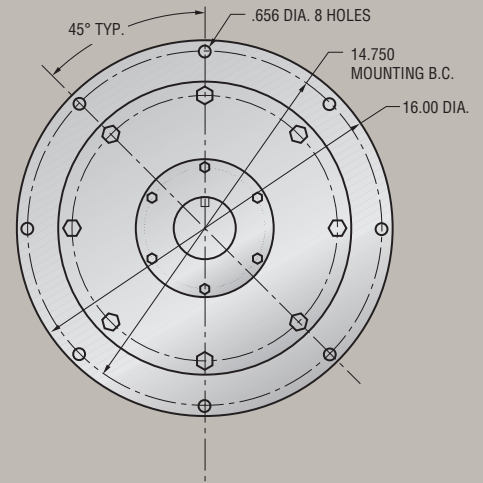
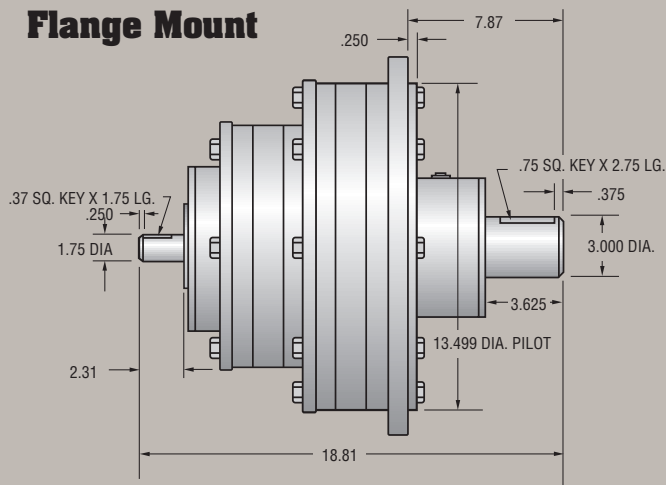

### Foot Mount

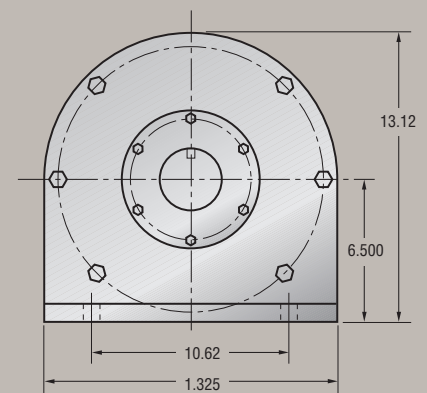
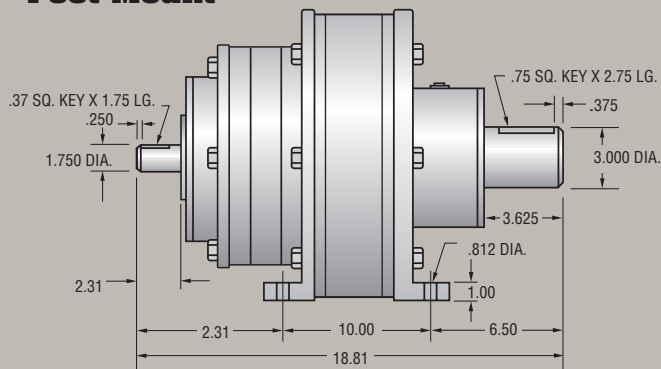

### Flange or Foot Mount w/SAE or NEMA Input

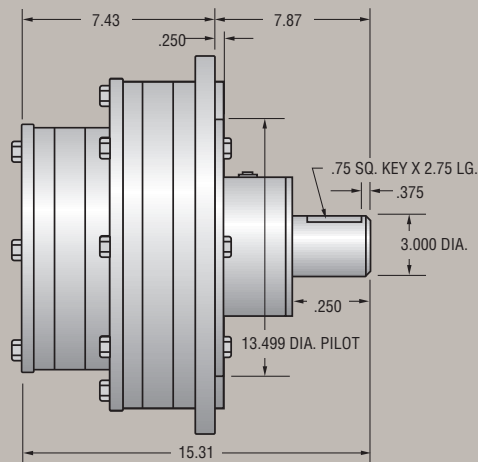

#### NEMA Electric Motor Direct Mount

"C" face direct couple of motor to speed reducer. No need for coupling or special motor mounts.

#### SAE Hydraulic Motor Direct Mount

2 bolt or 4 bolt direct couple of hydraulic motor to speed reducer. No need for coupling or special motor mounts.



*Byrne*  
**Gear Corporation  
of America**

- Planetary speed reducers
- High-speed increasers
- Custom design geared products

*"The Problem Solver"*

# Model 90-110

## Double Reduction Planetary Gear Reducer

Planetary Assembly	Ratios	OUTPUT HORSE POWER RATINGS (Adjusted for Thermal Efficiencies)						
		INPUT R.P.M.						
		100	580	720	870	1170	1430	1750
EE	9.00	5.06	17.33	20.16	23.01	28.32	32.59	37.54
EA	10.50	6.86	23.48	27.32	31.18	38.37	44.16	50.86
EB	12.00	6.14	21.02	24.45	27.92	34.35	39.53	45.54
AA	12.25	6.16	21.08	24.52	28.00	34.45	39.64	45.66
CE	12.99	3.92	13.40	15.59	17.80	21.90	25.21	29.03
AB	14.00	5.51	18.87	21.95	25.06	30.84	35.49	40.88
CA	15.17	5.30	18.15	21.12	24.11	29.66	34.14	39.32
BB	16.00	5.02	17.19	19.99	22.83	28.09	32.32	37.23
CB	17.33	4.75	16.25	18.90	21.58	26.56	30.56	35.20
DE	18.00	3.12	10.67	12.41	14.17	17.43	20.06	23.11
CC	18.78	3.33	11.40	13.26	15.14	18.63	21.44	24.70
DA	21.00	4.22	14.45	16.81	19.20	23.62	27.18	31.31
DB	24.00	3.78	12.94	15.05	17.19	21.15	24.34	28.03
DC	26.00	2.65	9.08	10.56	12.06	14.84	17.07	19.67
DD	36.00	2.03	6.95	8.08	9.23	11.35	13.06	15.05

Ratings based upon uniform steady and moderate shock loading. See load factor chart for details.

OUTPUT SHAFT RADIAL (overhung) LOAD CAPACITIES (at output r.p.m.)								
R.P.M.	10	20	30	50	100	200	300	500
Radial Capacity (lbs.)	17,000	13,600	11,900	10,200	8,500	8,075	6,800	5,525

OUTPUT SHAFT THRUST LOAD CAPACITIES (at output r.p.m.)								
R.P.M.	10	20	30	50	100	200	300	500
Thrust Capacity (lbs.)	26,025	20,842	18,724	16,060	13,049	10,602	9,386	8,050

**OUTPUT SHAFT MAXIMUM CONTINUOUS TORQUE CAPACITY:** 37,761 lb./inches  
**OUTPUT SHAFT INTERMITTENT TORQUE CAPACITY:** 75,440 lb./inches  
**WEIGHT:** 260 lbs.  
**RATING SYSTEM:** All Ratings Based Upon American Gear Manufacturers' Association Standards



*Byrne*

*"The Problem Solver"*

Part of The Byrne Group

Copyright © Byrne Gear Corporation of America  
 Printed in U.S.A. 697

**GEAR CORPORATION OF AMERICA**

301 Byrne Gear Drive  
 P. O. Box 1789  
 Mansfield, Ohio 44901  
 Telephone: (419) 522-GEAR(4327)  
 Fax: (419) 525-2386  
 E-mail: byrne@byrnegroup.com  
 Visit our web site at: www.byrnegroup.com